

LOC		DIST		REVISONS			
GP	00	F	LTR	DESCRIPTION	DATE	DMN	APVO
C				REVISED PER ECO-12-022391	02JAN2013	CJV	SLB

- △ HOUSING: NYLON, THERMOPLASTIC, UL 94VO RATED, BLACK.  
SHELL: CARBON STEEL.  
PIN CONTACTS: BRASS.  
EYELETS: BRASS.  
SCREWLOCKS: ZINC.  
BOARDLOCKS: COPPER ALLOY.
- △ PIN CONTACTS: 0.76µm[.000030] MIN GOLD PLATE ON THE MATING SURFACES, 2.54µm[.000100] MIN TIN PLATE ON THE SOLDER END, 1.27µm[.000050] MIN NICKEL UNDERPLATE ON THE ENTIRE CONTACT  
-OR-  
GOLD FLASH OVER PALLADIUM-NICKEL PLATE, 0.76µm[.000030] MIN TOTAL ON THE MATING SURFACES, 2.54µm[.000100] MIN TIN PLATE ON THE SOLDER END, 1.27µm[.000050] MIN NICKEL UNDERPLATE ON THE ENTIRE CONTACT.  
EYELETS: 2.54µm[.000100] MIN TIN OVER COPPER FLASH.  
SHELL: 2.54µm[.000100] MIN TIN OVER 1.27µm[.000050] MIN COPPER.  
SCREWLOCKS: CLEAR CHROMATE.  
BOARDLOCKS: 3.81µm[.000150] MIN TIN OVER 1.27µm[.000050] MIN NICKEL.
- △ DATUMS AND BASIC DIMENSIONS ESTABLISHED BY CUSTOMER.
- △ POSITION TOLERANCE APPLIES AT CONTACT TIP.
- △ BOARDLOCKS WILL ACCEPT .062 MAX PRINTED CIRCUIT BOARD THICKNESS.
- 6. COMPATIBLE WITH SOLDERING APPLICATIONS TO A MAXIMUM OF 225°C FOR A MAXIMUM DURATION OF 90 SECONDS. TEMPERATURE TO BE MEASURED ON CONNECTOR SURFACE.

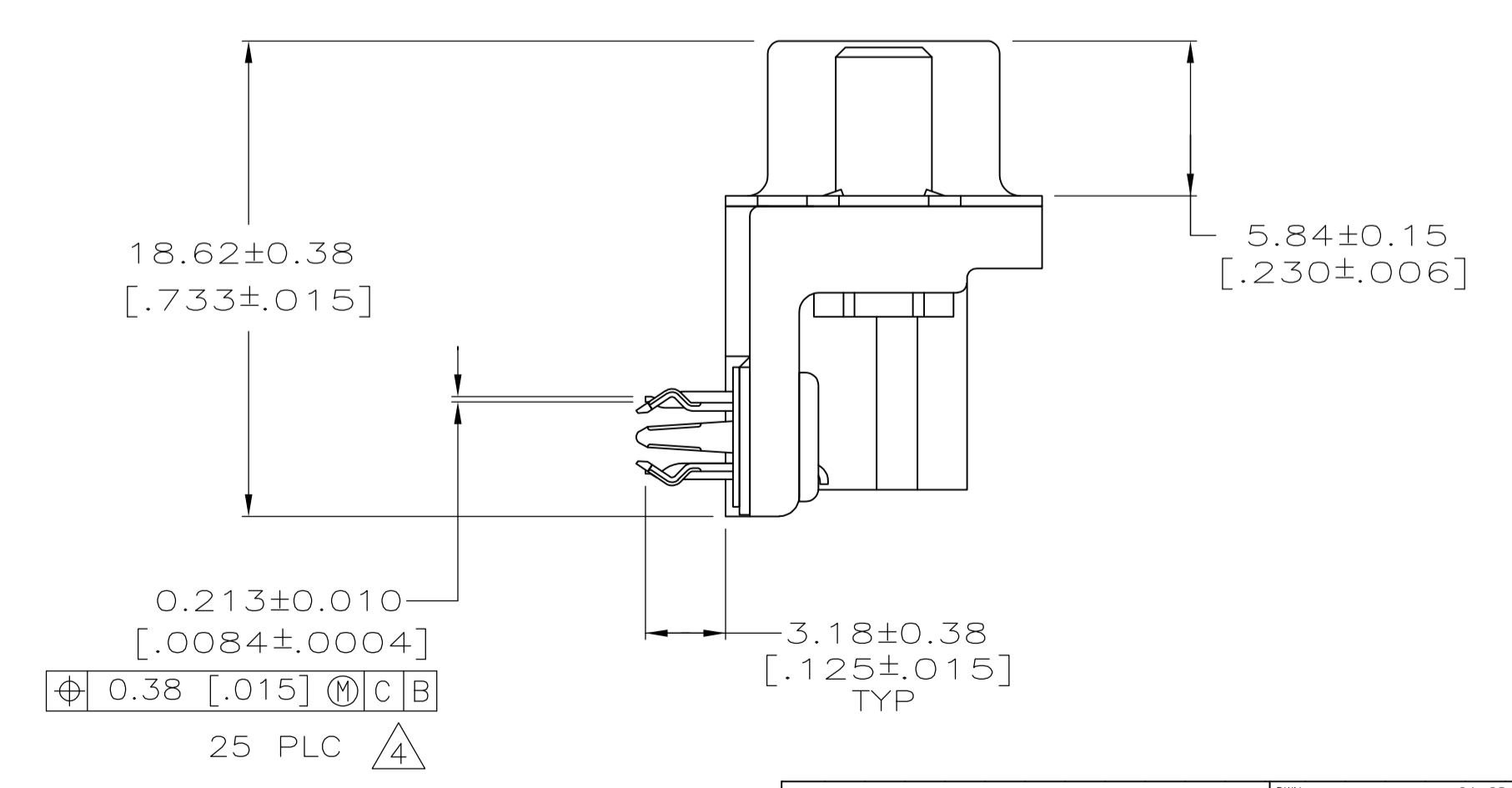
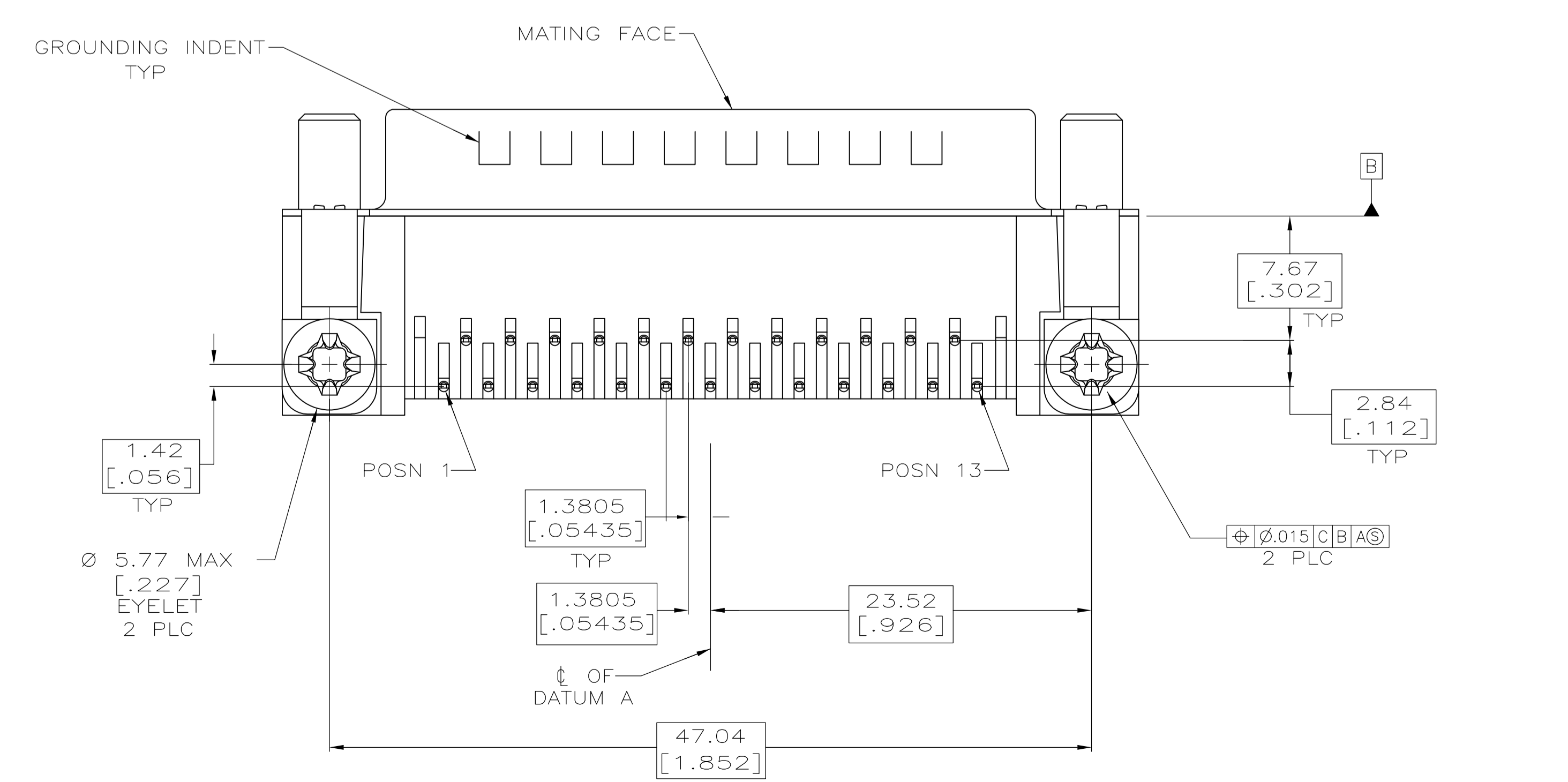
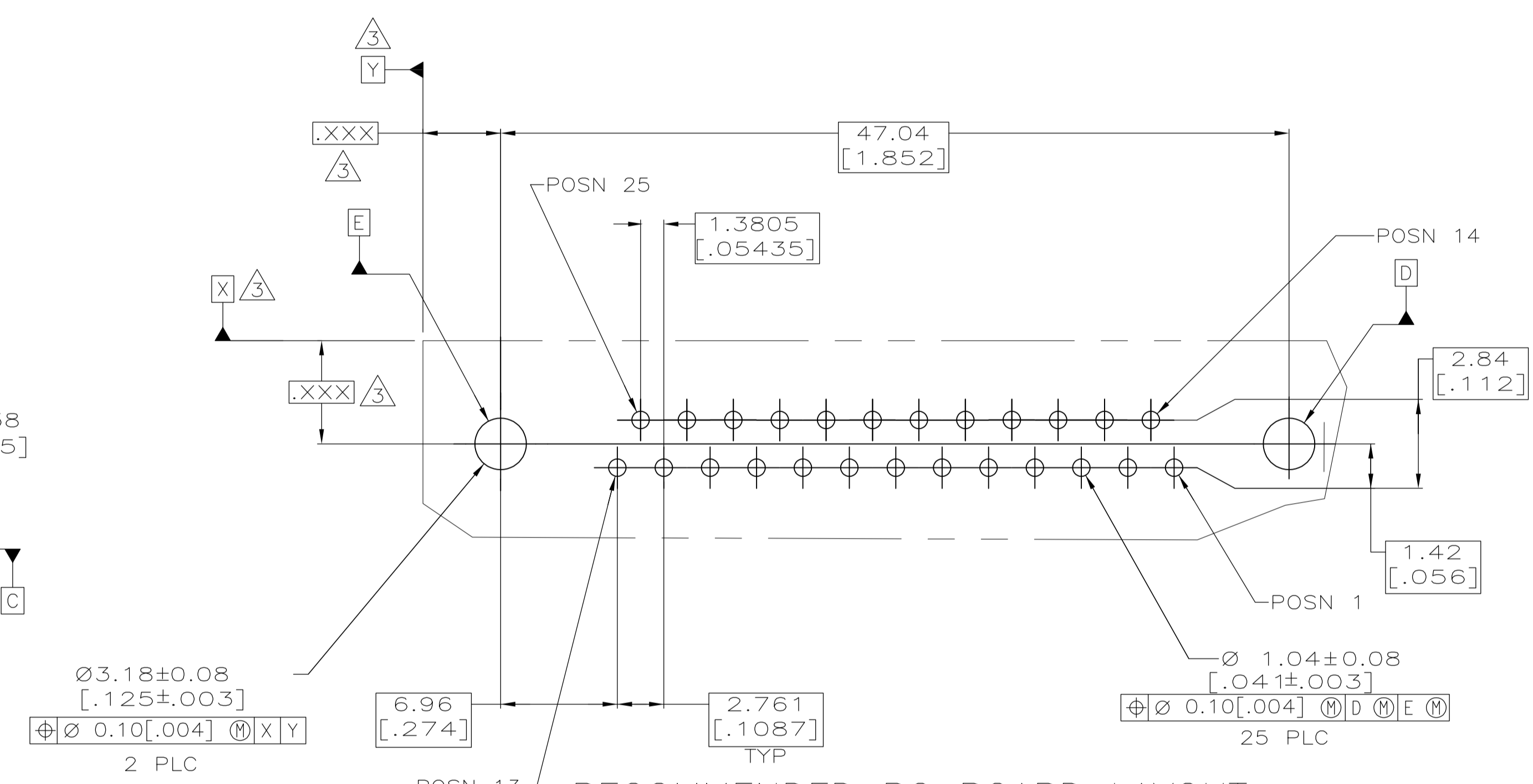
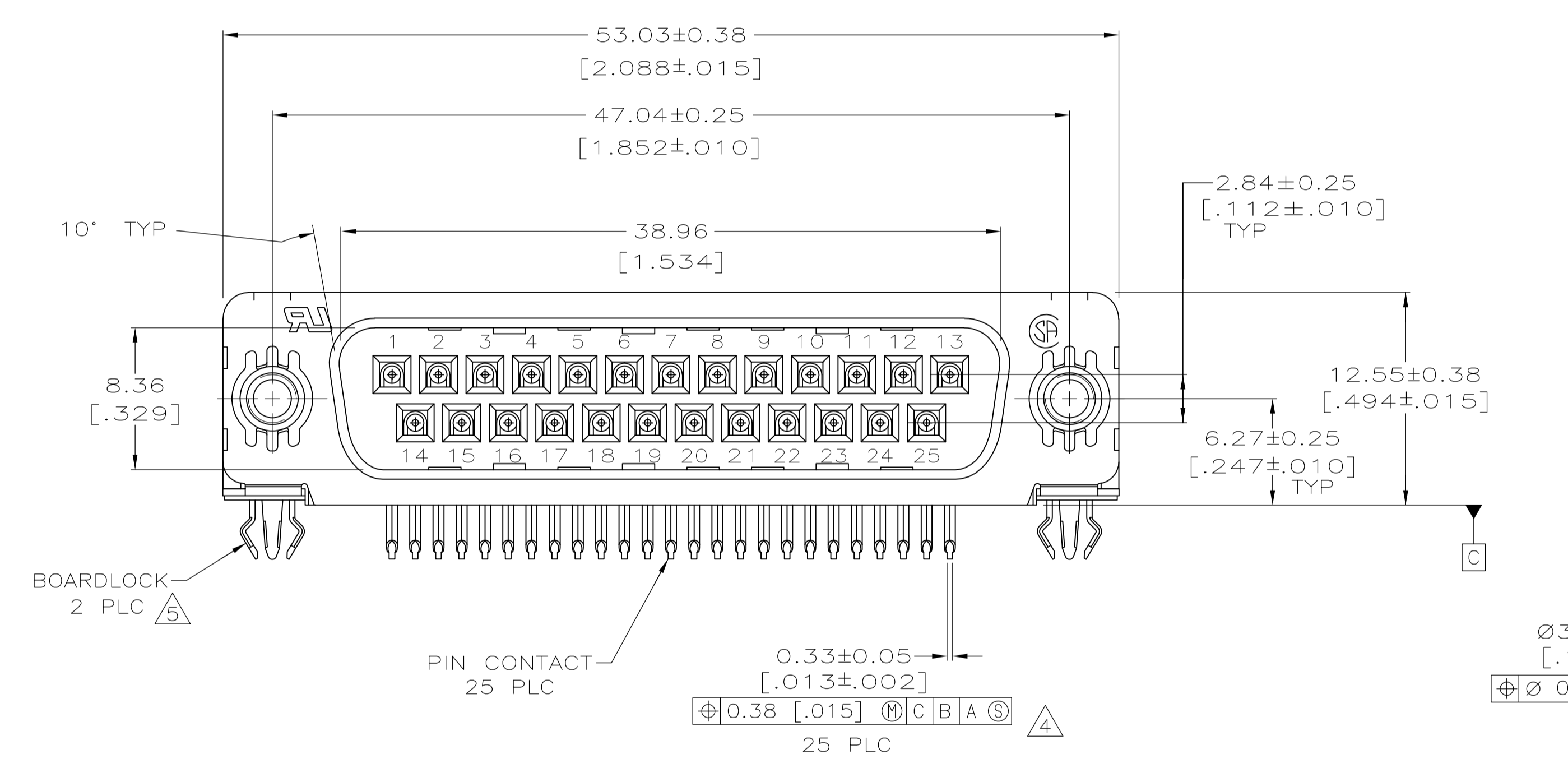
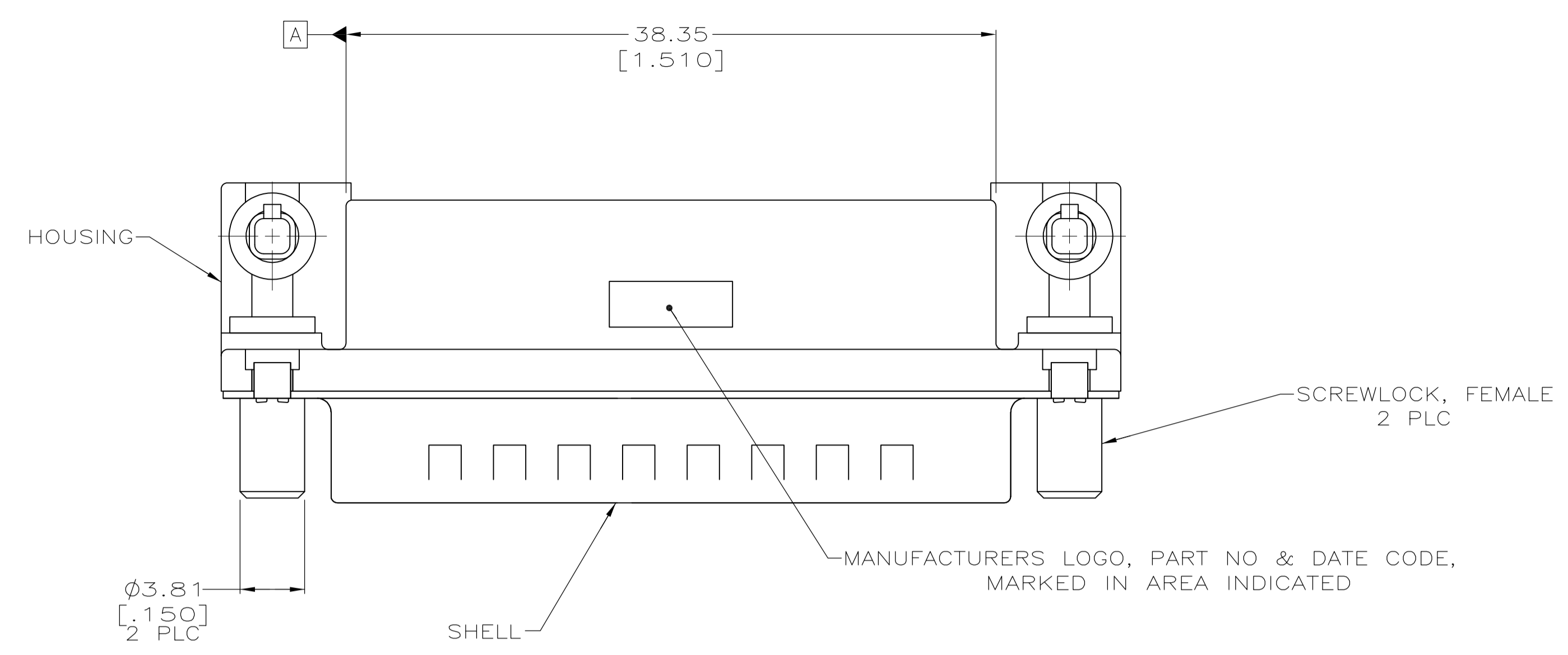

**COPYRIGHT 2005 TYCO ELECTRONICS CORP ALL RIGHTS RESERVED**

THIS DRAWING IS A CONTROLLED DOCUMENT. DIMENSIONING AND TOLERANCING PER ASME Y14.5M-2009		DIN J. ALCORTA - 04-08-05 DOCK5		S. BOLASH 04-08-05		M. WALMSLEY 04-08-05		NAME		5788795-1 PART NO	
DIMENSIONS: mm [INCHES]		TOLERANCES UNLESS OTHERWISE SPECIFIED:		PRODUCT SPEC		APPLICATION SPEC		SIZE		RESTRICTED TO	
Ø		0 PLC ± -		108-40025		114-40010		A1		CUSTOMER DRAWING	
Ø		1 PLC ± -		HIGH TEMPERATURE, AMPLIMITE HD-20		SCALE 4:1		SHEET 1 OF 1		REV C	
Ø		2 PLC ± 0.13 [.005]		WEIGHT		SCALE 4:1		SHEET 1 OF 1		REV C	
Ø		3 PLC ± -		CAGE CODE DRAWING NO		SCALE 4:1		SHEET 1 OF 1		REV C	
Ø		4 PLC ± -		CAGE CODE DRAWING NO		SCALE 4:1		SHEET 1 OF 1		REV C	
Ø		ANGLES ± °		CAGE CODE DRAWING NO		SCALE 4:1		SHEET 1 OF 1		REV C	
MATERIAL		FINISH		CAGE CODE DRAWING NO		SCALE 4:1		SHEET 1 OF 1		REV C	